



TESS100 DATASHEET

INTERNAL UNGUIDED TENSION SYSTEM

Freedom to move around curves. Any angle, any direction, anywhere.

Curved glazing presents tough challenges for most blinds. The TESS 100 overcomes these challenges without compromising on style. Relieving rollers allow the blind to follow the direction of the curve whilst ultra-thin cables maintain fabric tension. Unlimited colour finishes and a wide range of fabrics make it suitable for any project. Our single barrel mechanism keeps the fabric constantly under tension and produces a smooth, quiet travel.

- Single barrel tension system
- Any angle, any direction
- Curves and angles
- Discrete design
- Reliable and robust

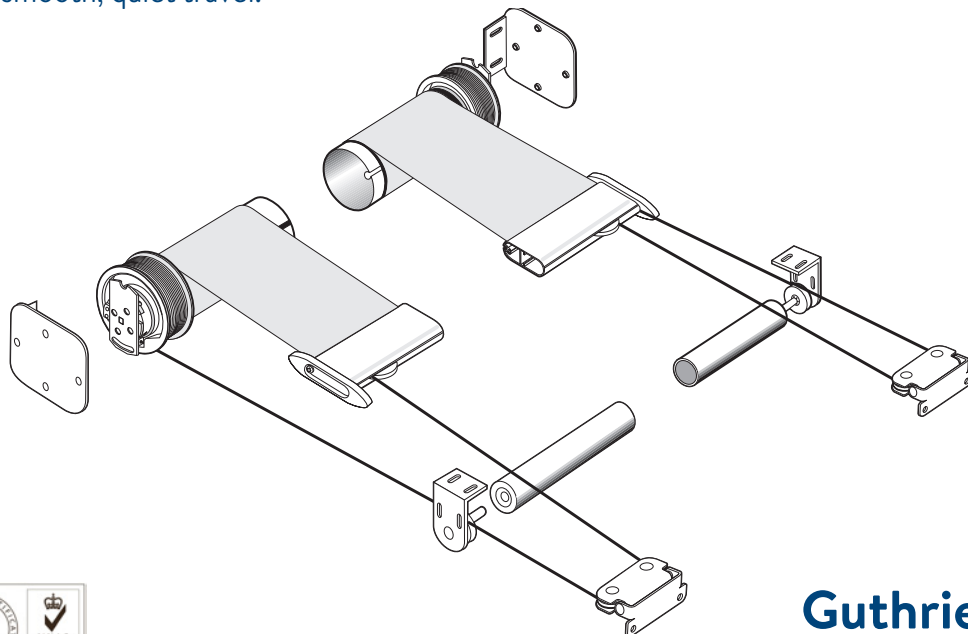

Guthrie Douglas

TOP FIX

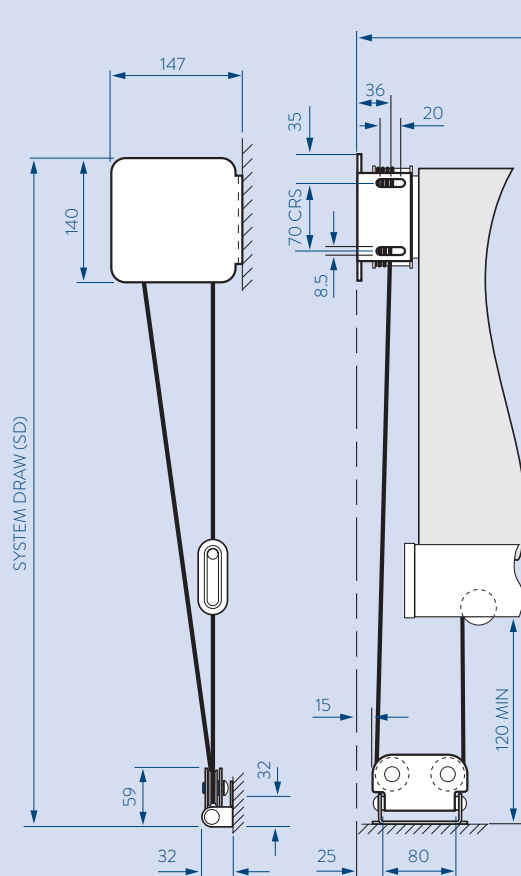

BACK FIX

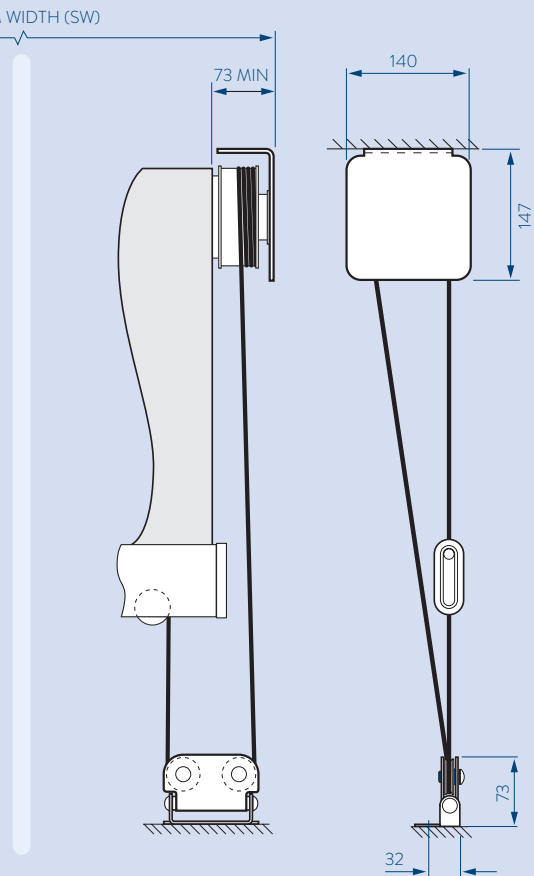

KEYFACTS

Typical use	Curved or vaulted glazing
Shape	Rectangular
Running direction	Any
Guides	None
Width	870 mm - 4000 mm
Draw	≤6500 mm
Fabric area	≤16 m ²
Brackets	Aluminium, stainless steel
Relieving rollers	Aluminium
Finish	RAL Powder coat
Installation options	Top, back

TECHNICALINFO

Fabric tension	>100 N
Weight exc. fabric	~7.5 kg + 4.2 kg/m width
Fixing load	≤36 kg per bracket
Operating temp.	0 to 55 °C
Motor	15 Nm, 17 rpm
Electrical	230 V, 50 Hz, 140 W, 0.65A 120 V, 60 Hz, 130 W, 1.1A
Max run time	4 min
Fabric speed	~5 m/min
Controls	Radio, Wired

