



TESS 600 DATASHEET

COMPACT UNGUIDED TENSION SYSTEM

Stylish solution for smaller spaces. Flat or sloped.

The compact headbox makes it easy to design into the glazing surround for near invisibility when retracted. Unlimited colour finishes and a wide range of fabrics make it suitable for any project. Our single barrel mechanism keeps the fabric constantly under tension and produces a smooth, quiet travel.

- Compact single barrel system
- Ultra-quiet motor
- Discrete design

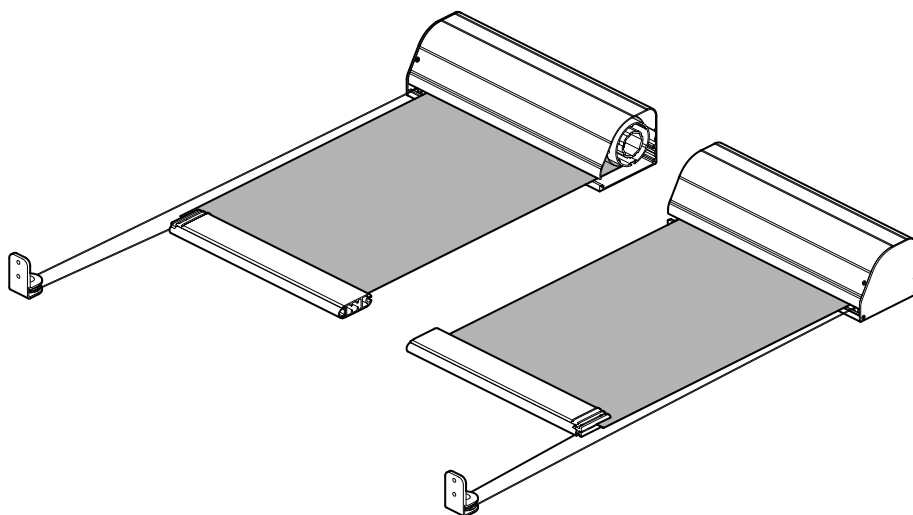

Guthrie Douglas

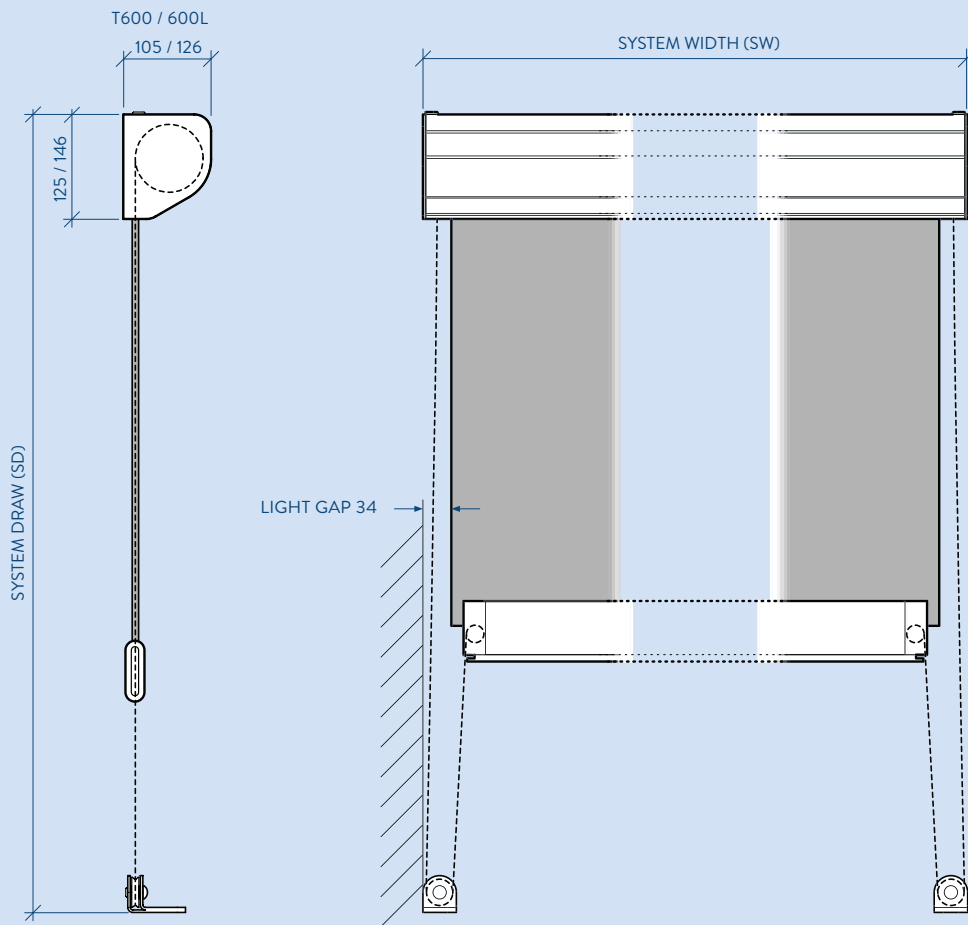

KEYFACTS

Typical use	Flat or sloped glazing
Shape	Rectangular
Running direction	Any
Guides	None
Width	650 mm - 3000 mm
Draw	≤3000 mm / ≤4500 mm
Fabric area	≤9 m ² / ≤13 m ²
Brackets	Aluminium
Relieving rollers	Aluminium
Finish	RAL Powder coat
Installation options	Top, back

TECHNICALINFO

Fabric tension	>100 N
Weight exc. fabric	~8 kg + 4 kg/m width
Fixing load	≤15kg per bracket
Operating temp.	0 to 55 °C
Motor	9 Nm, 12 rpm
Electrical	230 V, 50 Hz, 120 W, 0.55A
	120 V, 60 Hz, 130 W, 0.98A
Max run time	4 min
Fabric speed	~3 m/min
Controls	Radio, Wired

