

PRODUCTION	NO
PURCHASING	NO
SALES	NO
MARKETING	NO

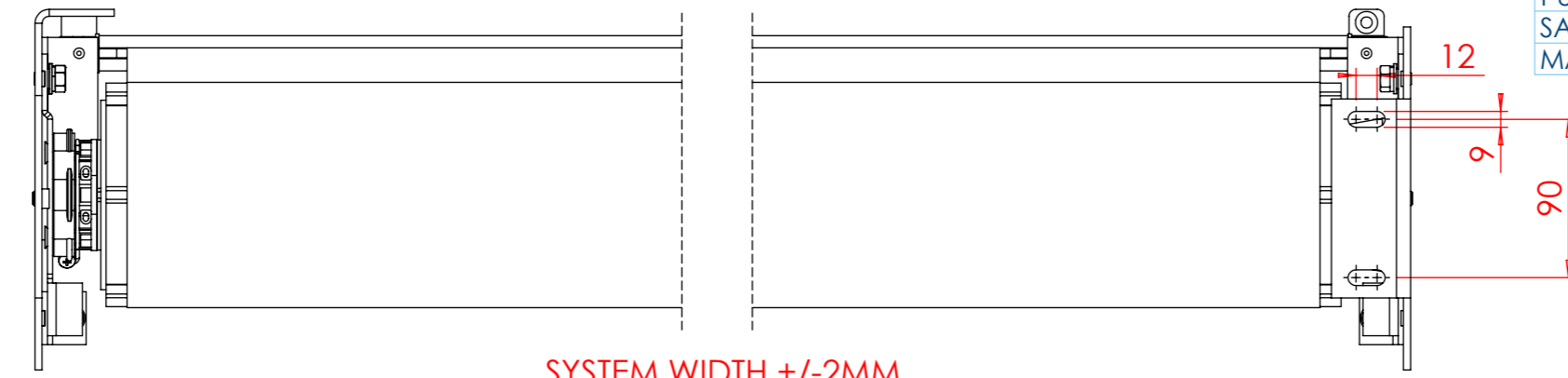

M8 FIXINGS
REQUIRED
(NOT SUPPLIED)

SYSTEM WIDTH +/-2MM
970MM MIN/ 5000 MAX

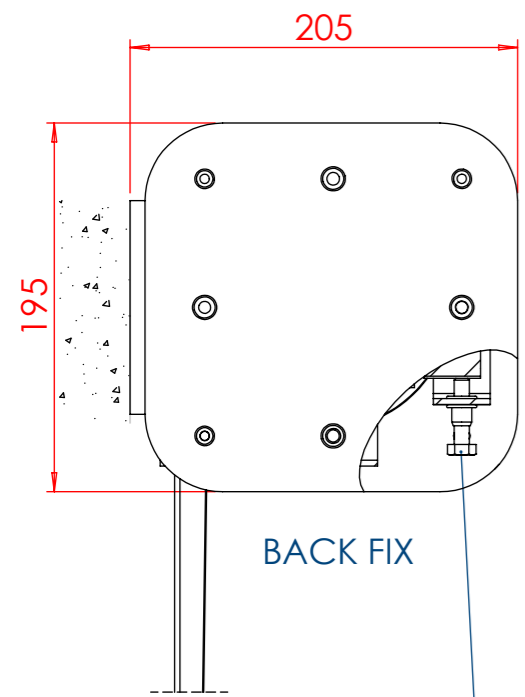

BACK FIX

TRACKING
ADJUSTMENT
SCREW

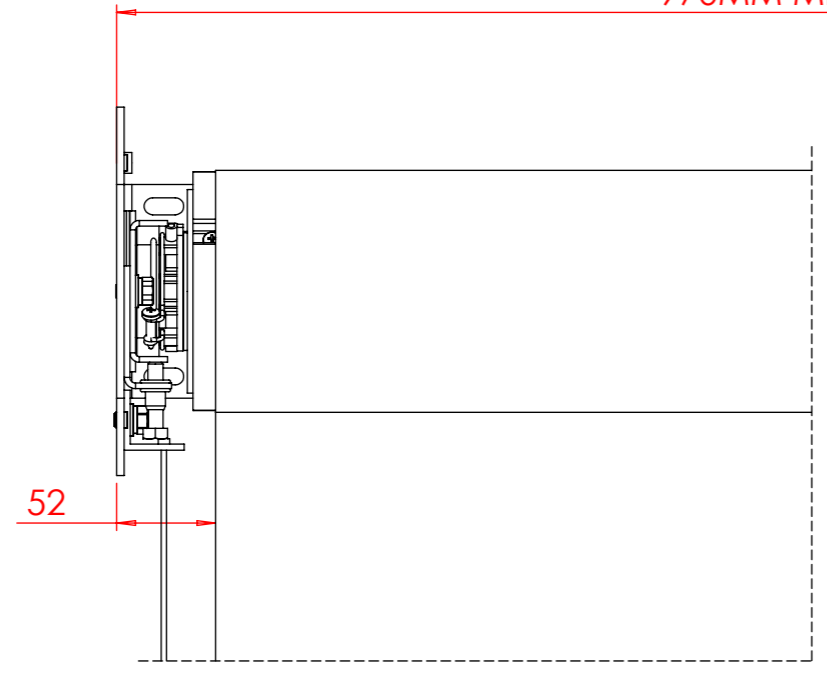

52

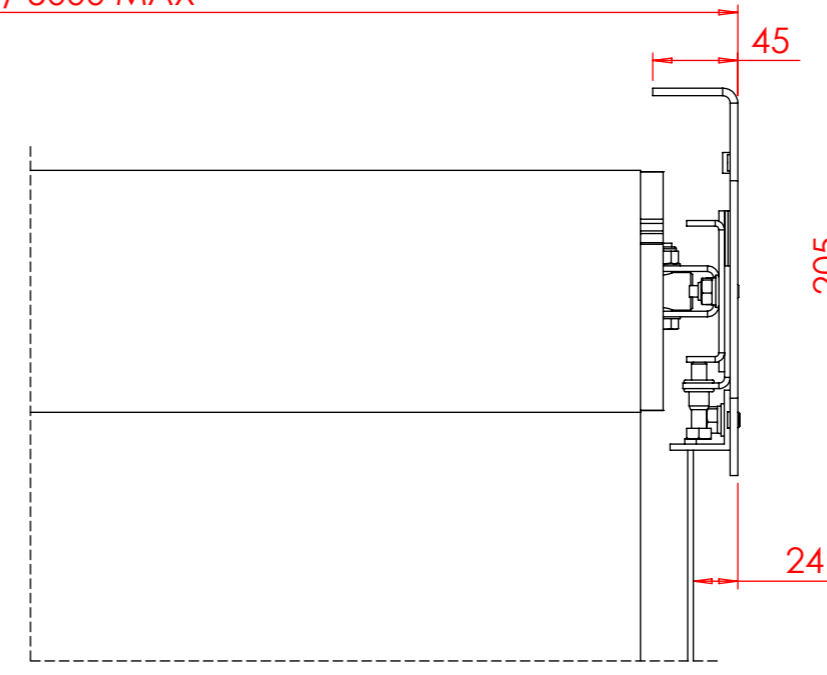

45

24

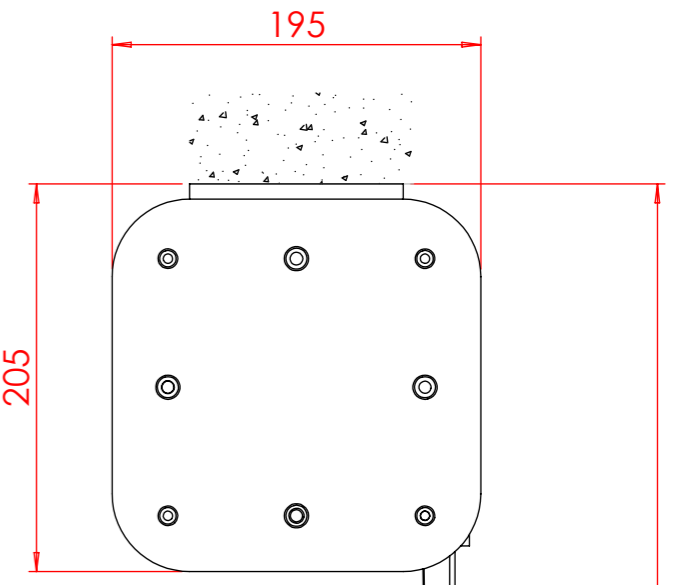

TOP FIX

SYSTEM DRAW
12M MAX

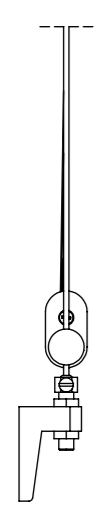

BACK FIX
ANCHOR

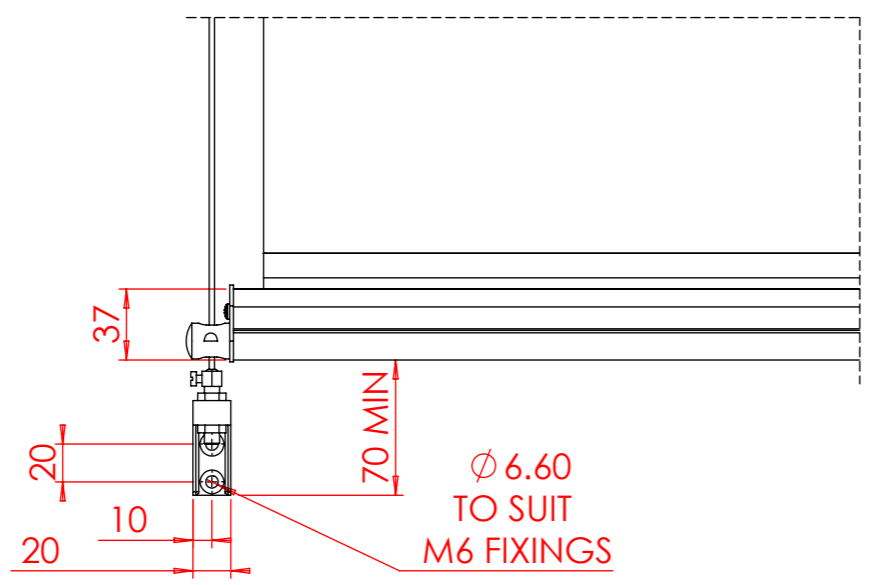

37

70 MIN

20

10

Ø 6.60
TO SUIT
M6 FIXINGS

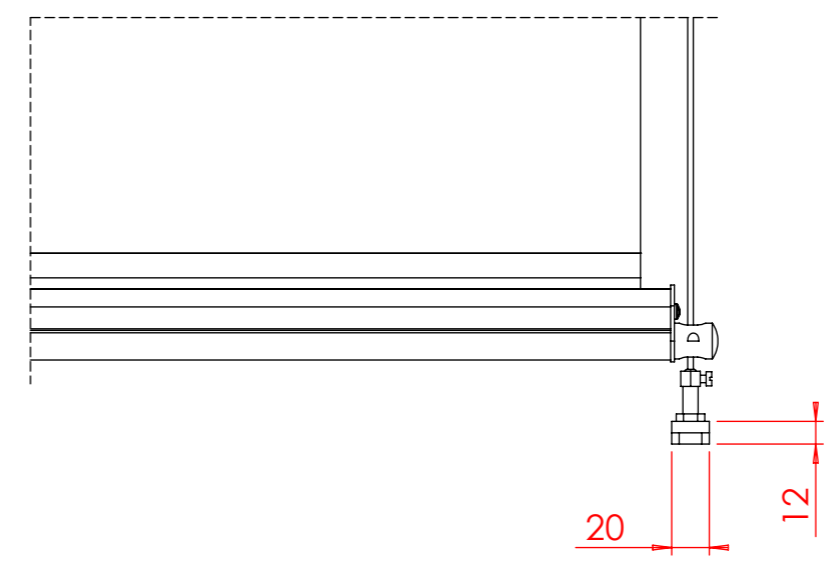

20

12

BOTTOM FIX
ANCHOR

50

THIRD ANGLE PROJECTION	
REMOVE ALL SHARP EDGES	
IF IN DOUBT ASK	DO NOT SCALE
GENERAL TOLERANCES TO ISO2768-m	
ALL DIMNS.IN mm	DRAWN TO BS308

This drawing is copyright and the exclusive property of GUTHRIE DOUGLAS GROUP LTD and must not be copied, used or exhibited without prior written consent.

Guthrie Douglas

12 Heathcote Way, Heathcote Industrial Estate,
Warwick CV34 6TE, UK
Tel : (01926) 310850 Fax : (01926) 832914

Customer			
Material	Scale	Size	
	1:4	A3	
Surface Finish	Special		

TESS 312

INSTALLATION DRAWING

Product Group		Item No.	
SOLAR		5983	
Drawn eng.trainee	Date 23-07-2013	Checked Samuel.Welsh	Date 22-03-2021
DRG.NO:			
GDP24593		/ 2	
SHEET 1 OF 1 SHEETS			