

TESS™ Quick Start

Installation Guide

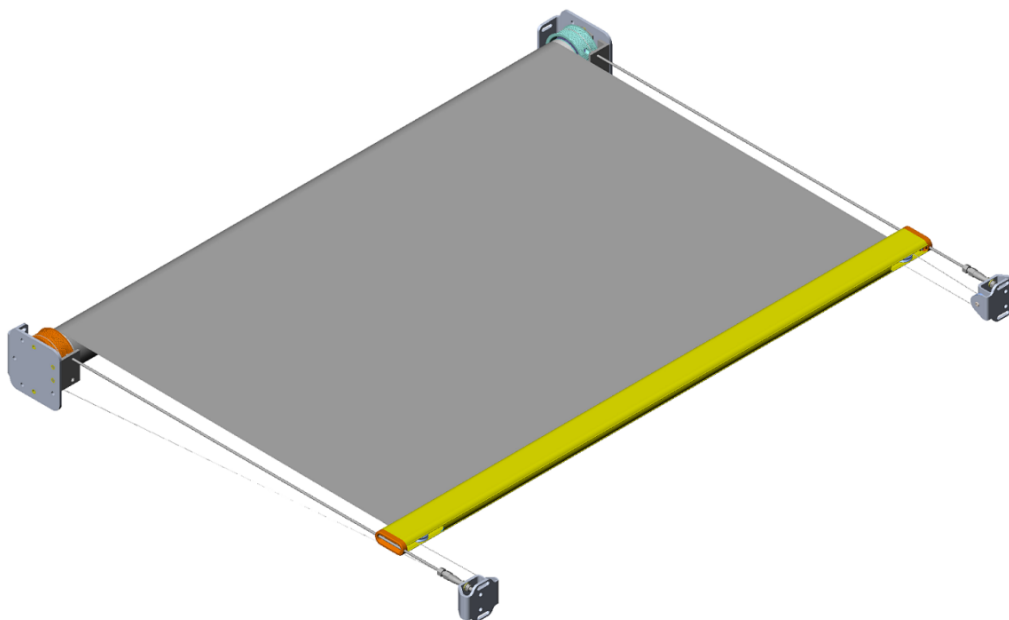

General information about TESS Systems

Guthrie Douglas TESS Systems are technical products that require installation, servicing and maintenance by professionals with the appropriate skills. If in doubt, please contact us for further advice and training.

This guide gives an overview of the typical stages needed to install a tensioned GD TESS system

All products are designed, tested, and manufactured in line with relevant EU regulations. General certificates of conformity and declarations of performance are available on our website or by Email

The product installer is responsible for ensuring that the installed product conforms to relevant standards and legislation.

Guthrie Douglas Group Limited

12 Heathcote Way

Heathcote Industrial Estate

Warwick

UK

CV34 6TE

E-mail: solar@guthriedouglas.com,

Web site: www.guthriedouglas.com

Tel: +44 (0)1926 310 850

Guthrie Douglas

1. Check the delivery and system reference

Check the system matches the order and site plan or reference.

The system will be labelled and produced as per the order details and will fit at a specific location. Systems should not be stretched or squeezed to fit alternative locations.

Check that all items are available before starting installation.

The system will always consist of;

- Barrel kit (barrel and hem bar; and fabric if supplied by GD)
- Barrel mounting kit (end plates or head box to suit order)
- Return pulley kit (pair to suit order)
- Barrel fixing kit
- Control cable (1.5mm diameter black plastic coated, length to suit system)

The System might include;

- Side guide cable or side guide profiles
- Relieving roller kits
- Tensioning tools

Ensure the installation manual and drawing is available for reference.

System fixings are never supplied by GD, installer to ensure their fixings are suitable. Fixings on some GD systems are required to withstand high pull-out forces.

2. Check and mark out the fixing positions

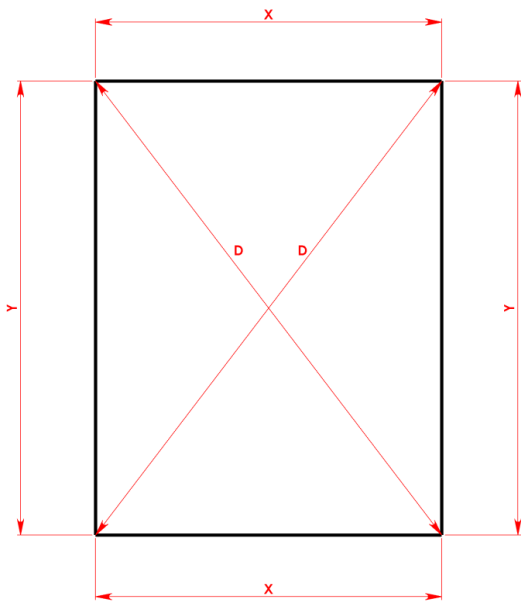

- For any roller fabric system to be reliable it must be installed square.
- Laser levels can be used.
- Laser and tape measurements can be used to check the setting out. Measure the system width (X) and system draw (Y) at both sides; both sides should be equal.
- Measure the system diagonals (D) they should be equal.
- It is possible for X and Y to be equal at opposite sides and for the diagonals (D) to be unequal. If so make adjustments to the setting out.

3. Install the barrel mountings

- Refer to the installation drawing
- Produce fixing holes in the correct positions
- Lightly fit the barrel mountings (end plates or head box)
- The fixing will be through slots; adjust mountings so that the positions are correct as per stage 2
- If using end plates; check the dimension is correct across system width. Refer to installation drawing and order reference
- Fully fix the barrel mountings

4. Install the barrel

- Refer to installation manual
- Fit fabric if required
- Use fixings supplied in the fixing kit
- If tracking plates are used clamp the barrel so that the tracking plate is at the mid-position on both sides

5. Install the return pulleys

- Refer to the installation drawing
- Produce fixing holes in the correct positions
- Lightly fit and adjust in slots so that the position is correct as per stage 2
- Fully fix the pulleys

6. Fit side guides (Option)

- Cable guides are fitted after return pulleys
 - Guide cables are cut to length at site; take care not to cut too short
 - Measure across guide cables ensure the width is parallel
 - Ensure the width is equal to the holes in the hem
- Profiled aluminium guides contain return pulleys
 - Produce fixing holes
 - Set guides so that the system is square and the correct width

7. Fit control cable

- Control cable passes through the hem bar, one continuous cable is used
- When fitting to the cable spool ensure one full turn of cable is in place at each side when the system is fully retracted
- Control cable is fitted to the opposite side of the barrel to the fabric
- Tension the cable according to the installation manual
- Ensure the cable is correctly seated in all of the pulleys and at the outer edge of the spool

8. Commission the system

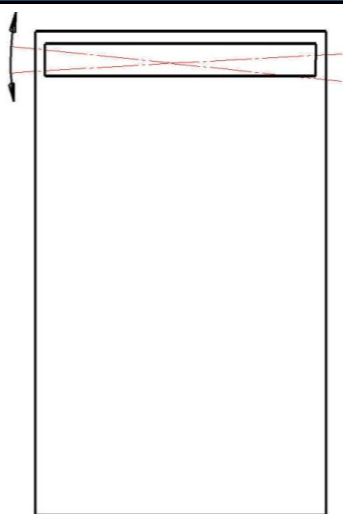

- The systems should be run several times or more
- Identify any mechanical issues and rectify
 - These are rare and often related to installation issues
- Identify any issues with fabric tracking
- These are common and are nearly always installation related
 - Most systems can be adjusted after commissioning
 - Slacken tracking screws after supporting the barrel (it is now under tension)
 - Adjust the barrel position and run the system after retightening the tracking screw
 - Repeat until fabric runs true (check on retract)
- Where systems don't use tracking plates the system layout must be correct, see section 2.

9. Motors and power

- Commission one system at a time using a test lead before connecting to mains
- When connected systems should be connected to individual switched spurs
- Radio motors should be commissioned with power only on at the system being commissioned
- For product support and training please contact Guthrie Douglas. See: www.guthriedouglas.com

Notes

Guthrie Douglas